

# McIntosh

## C 27 PREAMPLIFIER



## SERVICE INFORMATION

STARTING WITH SERIAL NO. BV1001

McINTOSH LABORATORY INC. BINGHAMTON, NEW YORK 13903

039-032

## FREQUENCY RESPONSE

+0 -0.5 dB 20Hz to 20,000 Hz

## DISTORTION

Will not exceed 0.05% at rated output level,  
20 Hz to 20,000 Hz.

## INPUT SENSITIVITY AND IMPEDANCE

AUXILIARY 1 and 2, TUNER, TAPE 1 and 2: 250 millivolts at 100 000 ohms

PHONO 1 and 2: 2 millivolts at 47K ohms and 100pF

## HUM AND NOISE

AUXILIARY 1 and 2, TUNER, TAPE 1 and 2: 85 dB unweighted; 90 dB IHF "A" weighted.

PHONO 1 and 2: 80 dB below 10 mV input, unweighted; 85 dB IHF "A" weighted.

## OUTPUT LEVEL AND IMPEDANCE

MAIN OUTPUT 2.5 volts with rated input, less than 1K ohms source impedance, to operate into 22K ohms load or higher. Maximum output is greater than 10 volts.

TAPE OUTPUT 0.25 volts with rated input, less than 1.5K ohms source impedance, to operate into 22K ohms load or higher. Maximum output is greater than 10 volts.

CENTER CHANNEL OUTPUT (L+R) 2.5 volts with rated input to both channels, less than 1.2K ohms source impedance, to operate into 22K ohms load or higher.

## VOLTAGE AMPLIFICATION IN DECIBELS

AUXILIARY 1 and 2, TUNER, TAPE 1 and 2 to MAIN OUTPUT 20 dB, to TAPE OUTPUT 0 dB

PHONO 1 and 2 to MAIN OUTPUT 62 dB, to TAPE OUTPUT 42 dB

## POWER REQUIREMENT

120 volts, 50/60 Hz, 15 watts

## MECHANICAL INFORMATION

SIZE: Front panel measures 16 inches wide (40.64 cm) by 5-7/16 inches high (13.81 cm). Chassis measures 15 inches wide (38.1 cm) by 5 inches high (12.7 cm) by 13 inches deep (33.02 cm), including PANLOC shelf and back panel connectors. Knob clearance required is 1-1/2 inches (3.81 cm) in front of the mounting panel.

FINISH: Front panel is anodized gold and black with special McIntosh gold/teal panel nomenclature illumination. Chassis is black

MOUNTING: Exclusive McIntosh developed professional PANLOC.

WEIGHT: 18 pounds (8.2 kg) net, 33 pounds (15.0 kg) in shipping carton

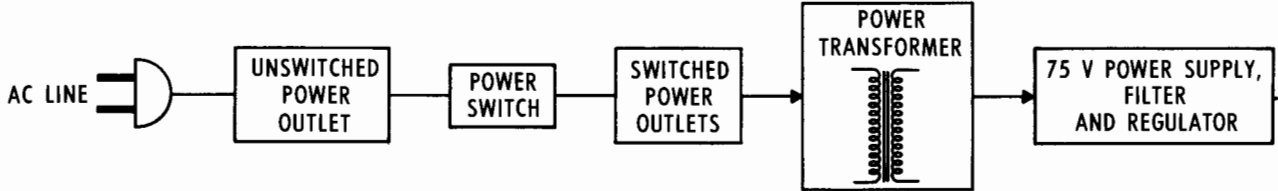
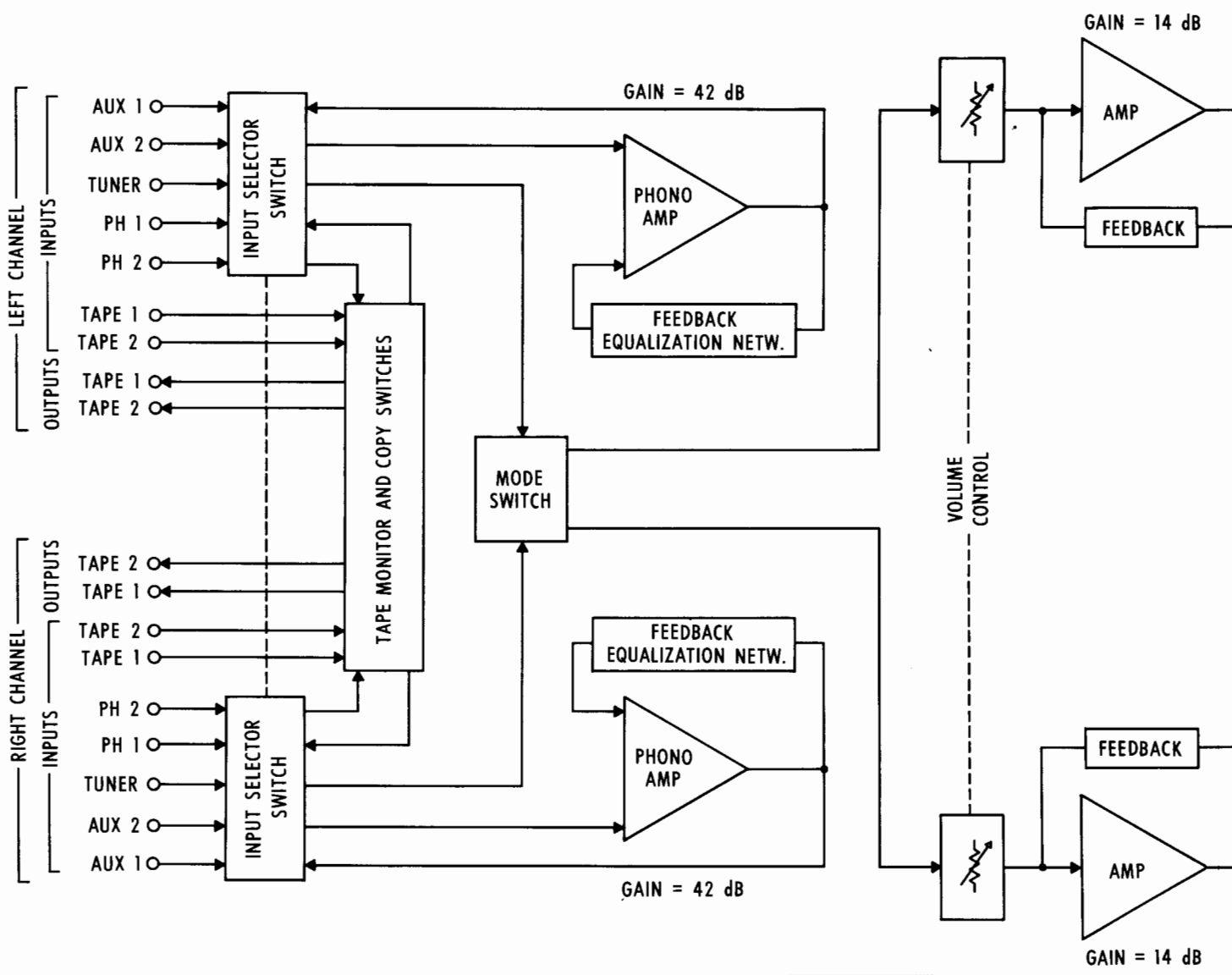

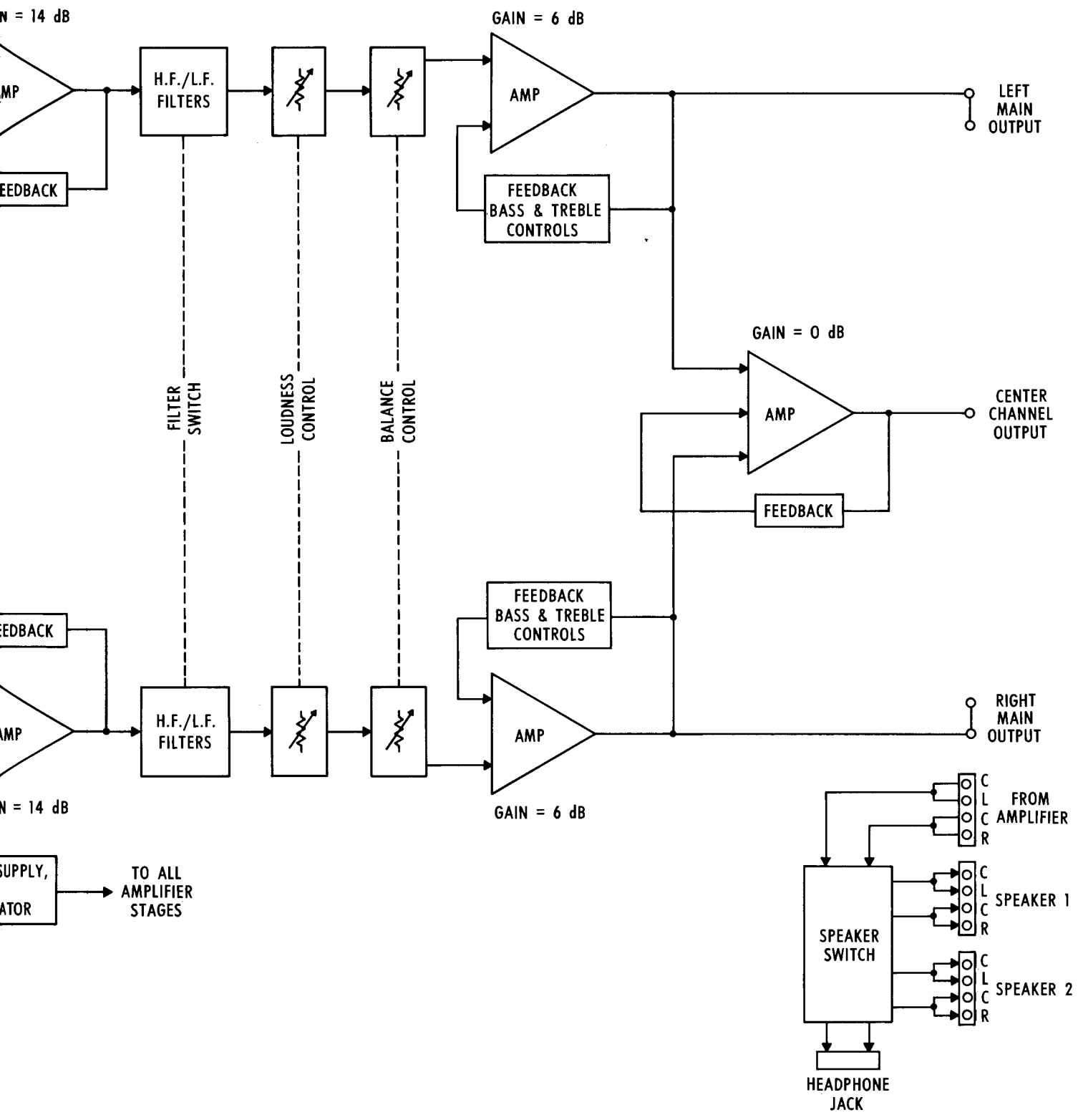

BLOCK DIAGRAM

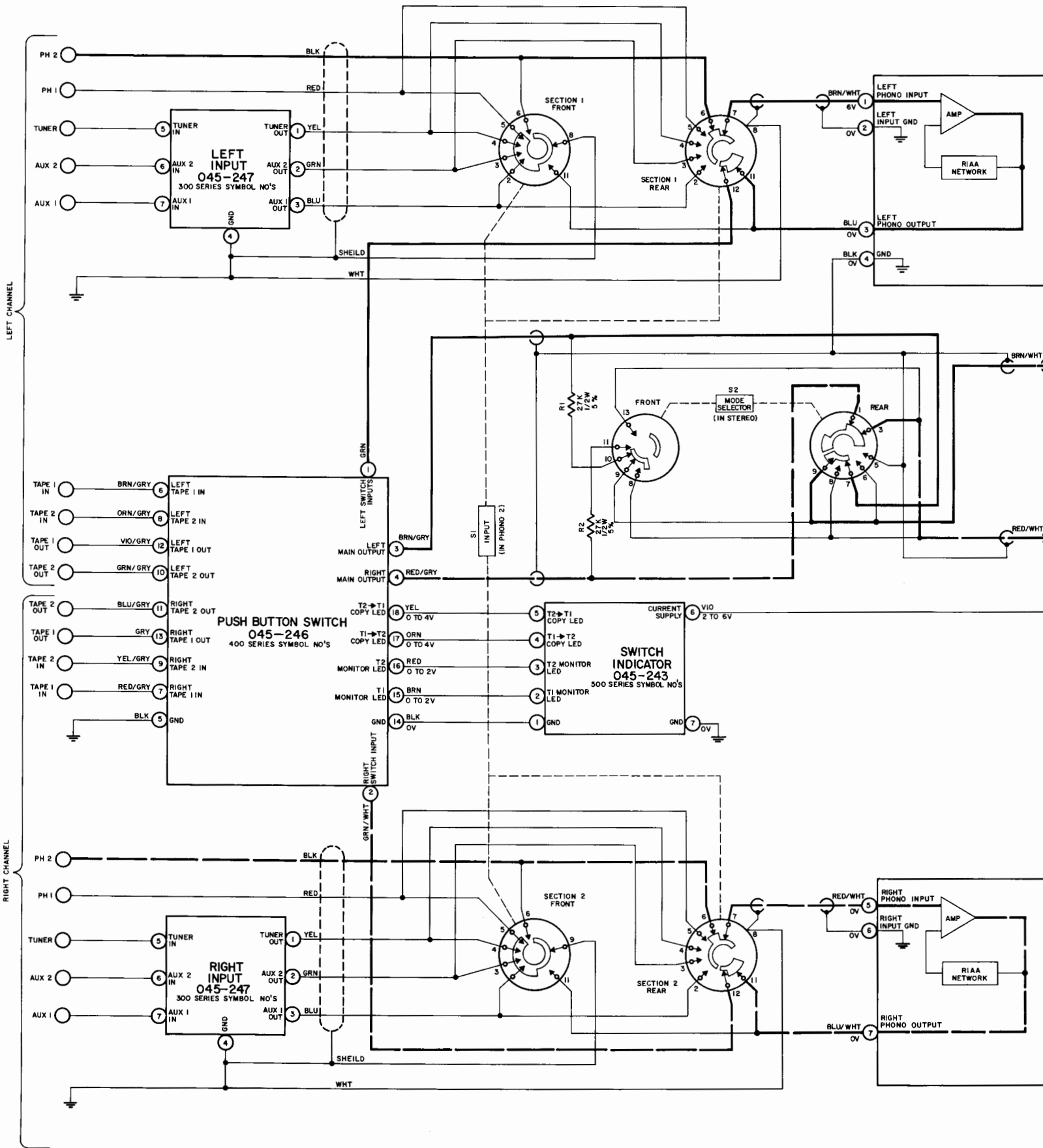

LEFT CHANNEL  
045-250  
100 SERIES SYMBOL NO'S

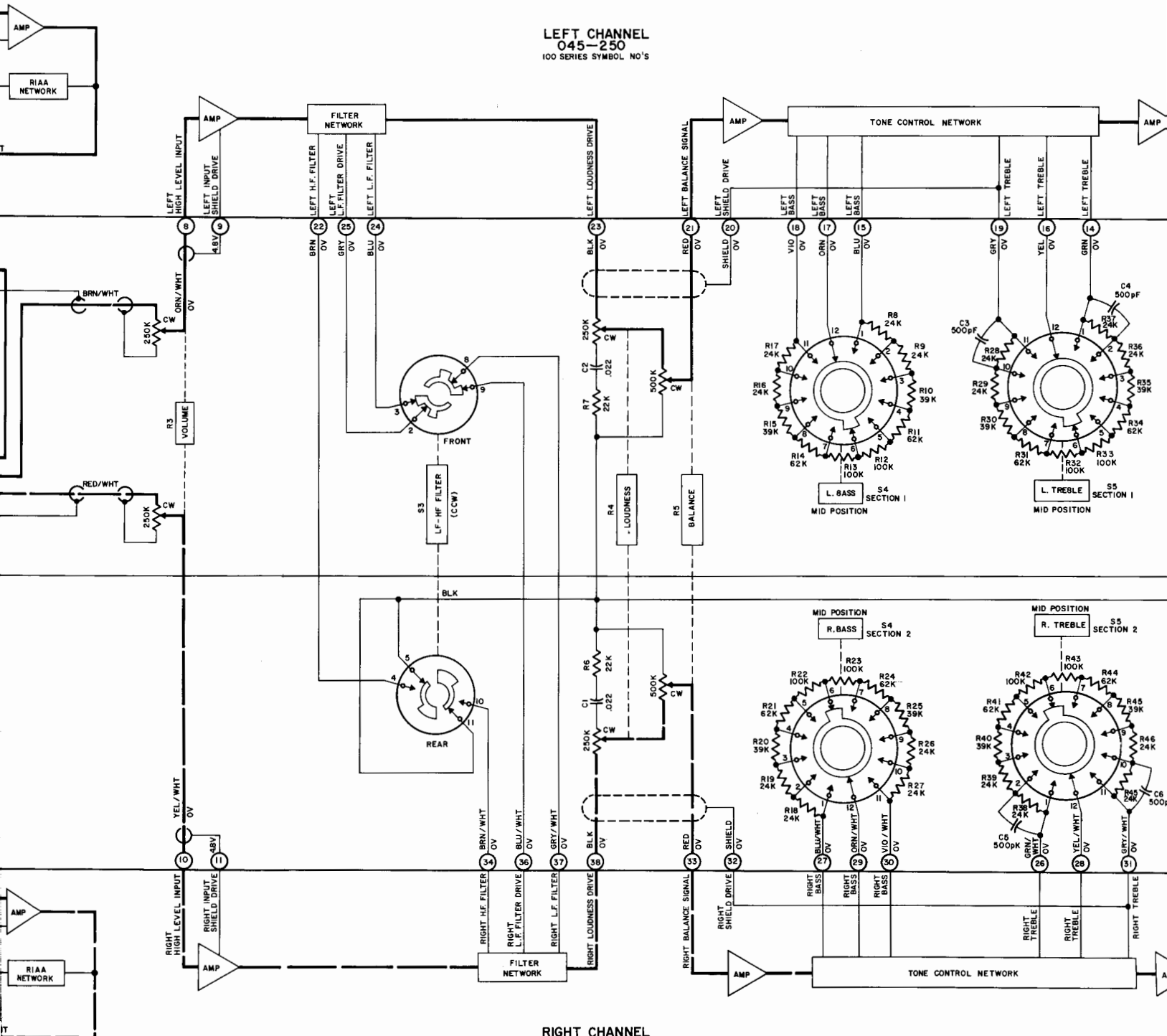

RIGHT CHANNEL  
045-250  
100 SERIES SYMBOL NO'S

POWER SUPPLY  
045-250  
200 SERIES SYMBOL NO'S

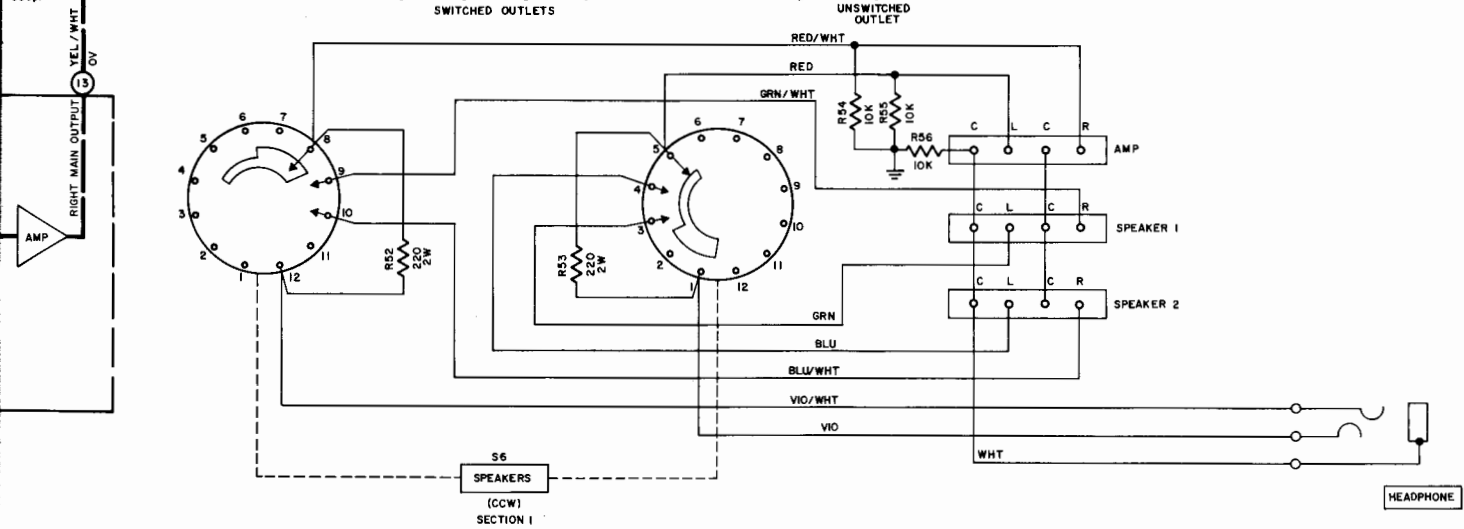
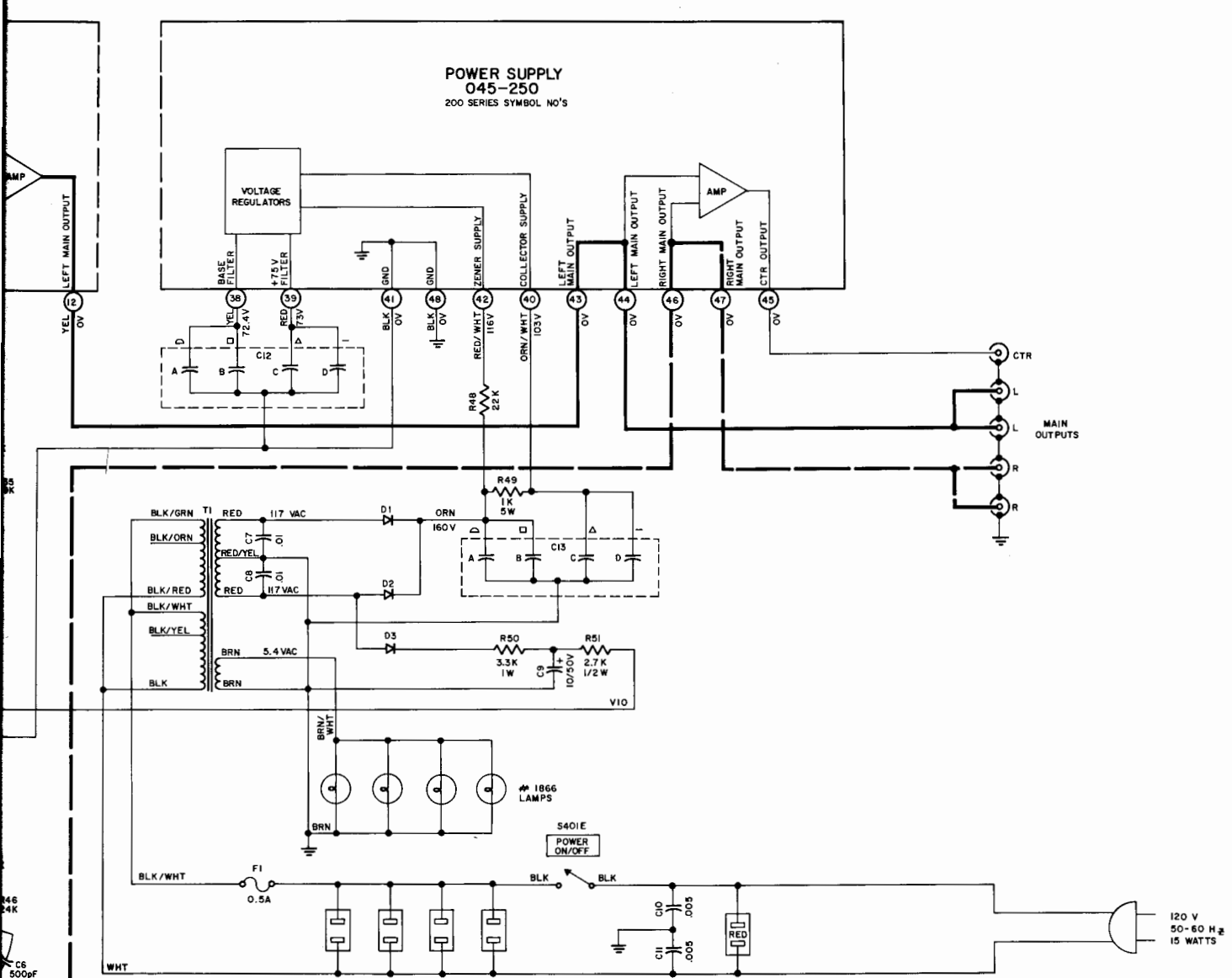

SPEAKERS  
(CCW)  
SECTION I

HEADPHONE

1. Unless otherwise specified: Resistance values are in ohms, 1/4 watt, and 5% tolerance; capacitance values smaller than 1 are in microfarads ( $\mu\text{F}$ ); capacitance values greater than 1 are in picofarads (pF); inductors are in microhenries ( $\mu\text{H}$ ).
2. Printed circuit board components are outlined on the schematics by dotted lines. The circled numbers around the dotted lines correspond to the numbers on the PC Board layouts.
3. The heavy lines on the schematics denote the left channel primary signal path. The heavy dash lines on the schematics denote the right channel primary signal path.
4. The terminal numbering of rotary switches is for reference only.
5. All voltages indicated on the schematics are measured under the following conditions:
  - a. Use of an 11 megohm input impedance VTVM.
  - b. All voltages  $\pm 10\%$  with respect to chassis ground.
  - c. No signal at input terminals.
  - d. AC input at 120 volts, 50/60 Hz.
  - e. Front panel controls at:

Speaker	Off
Filter	Out
Input Selector	Phono 1
Mode Selector	Stereo
Treble	Flat
Bass	Flat
Volume	ccw
Balance	Center Detent
Loudness	Flat
Push Switches	Out
Power Switch	On

All other controls at normal positions



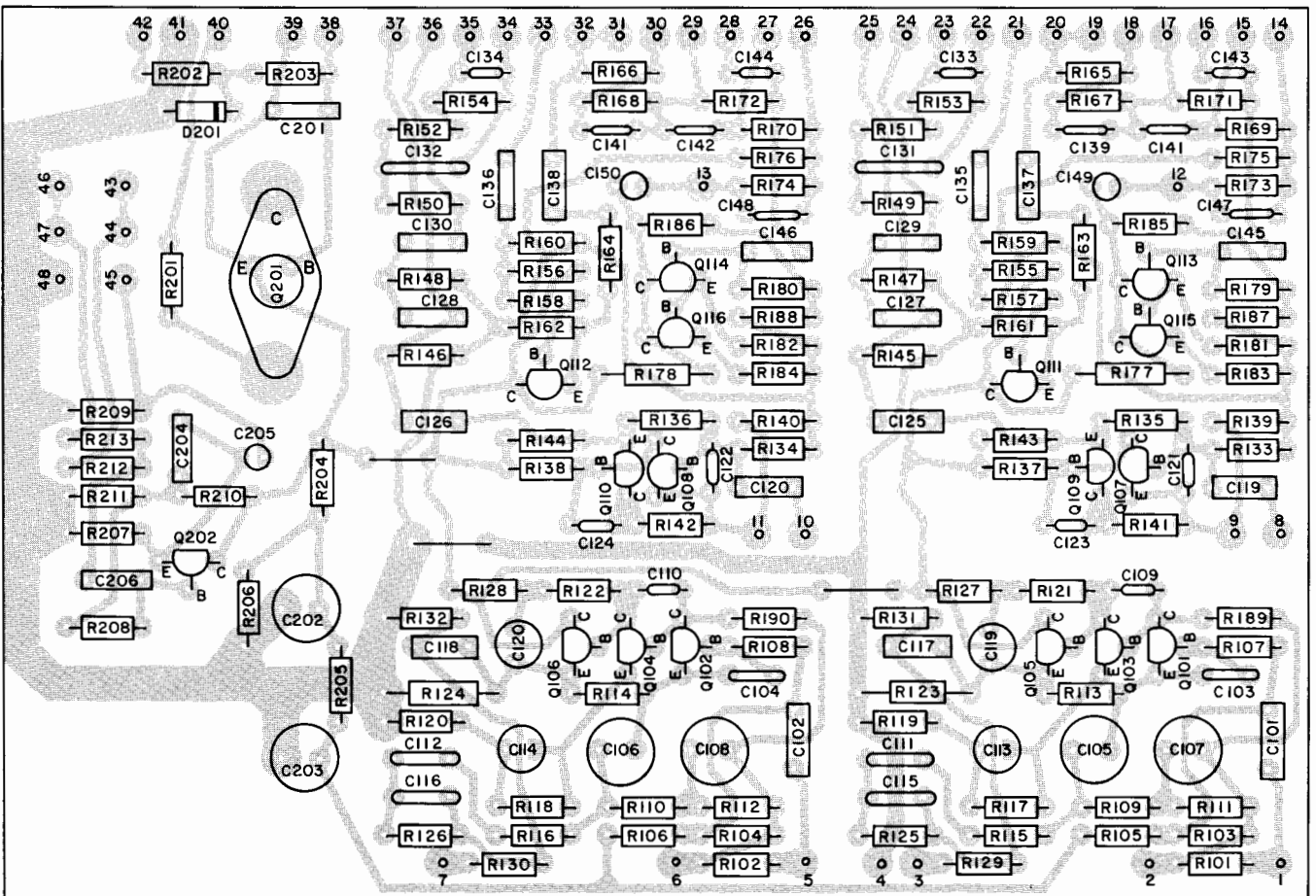
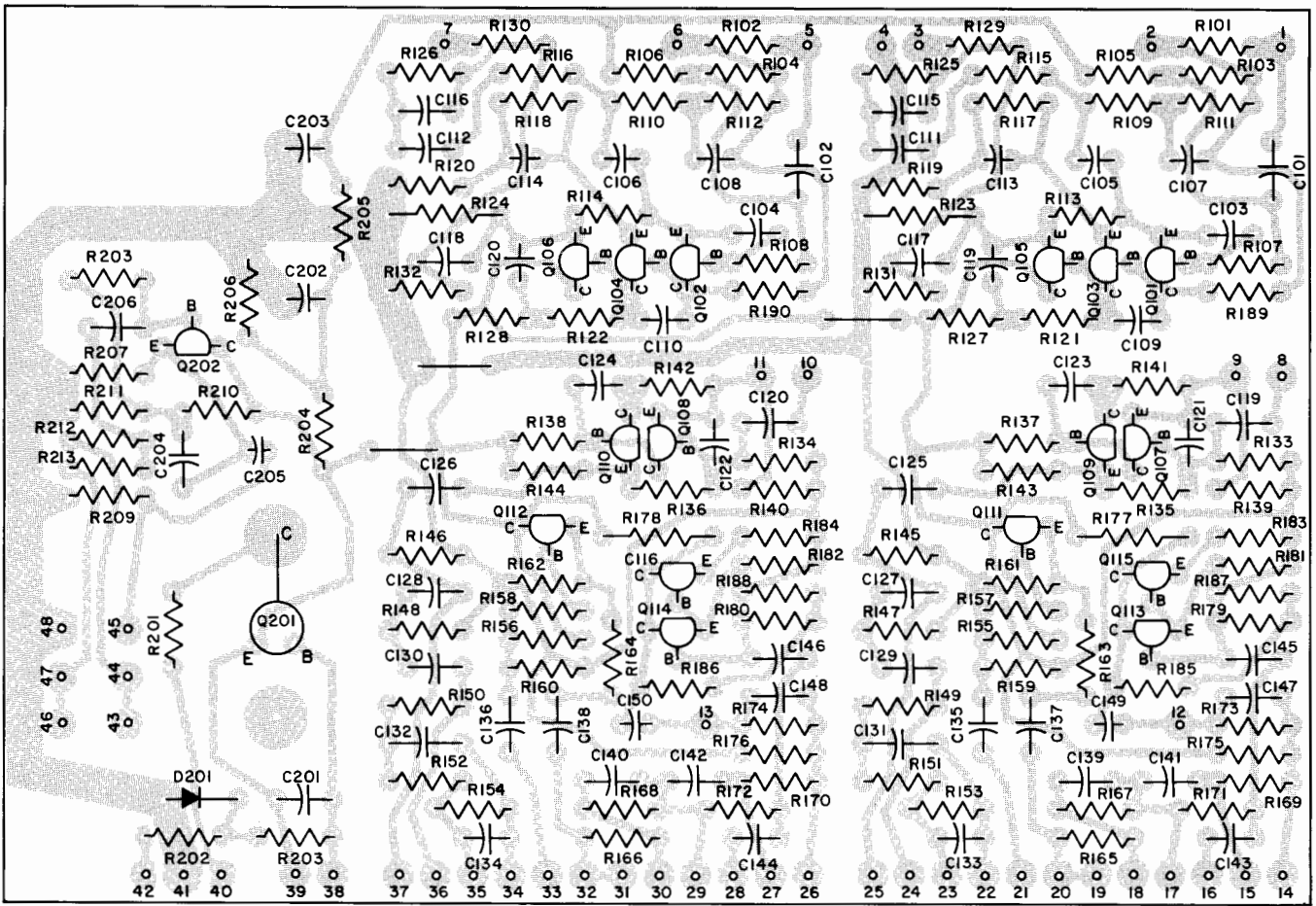

MAIN PC BOARD 045250

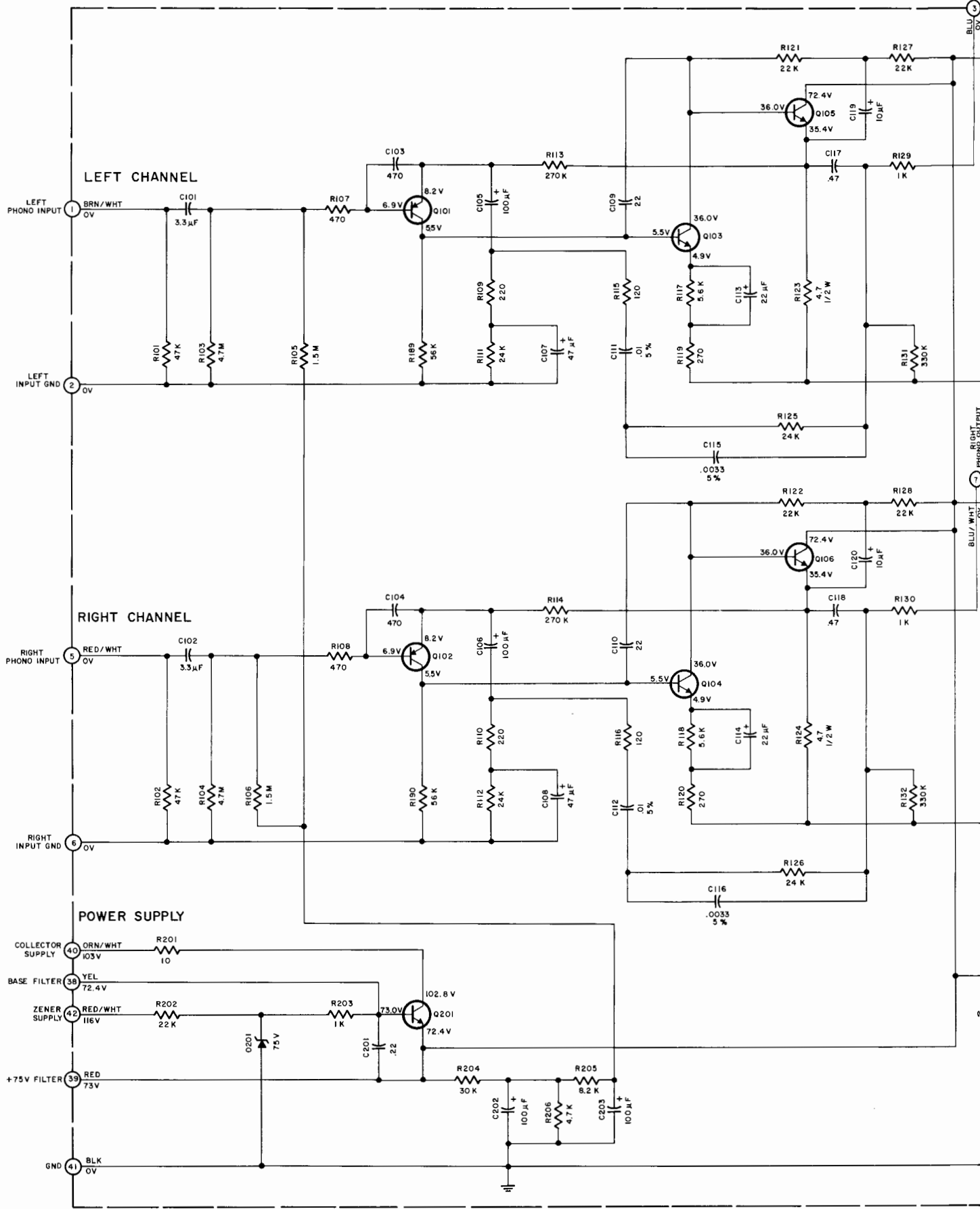

**LEFT CHANNEL**

**RIGHT CHANNEL**

**POWER SUPPLY**

LEFT PHONO INPUT (1) BRN/WHT OV  
LEFT INPUT GND (2) OV

RIGHT PHONO INPUT (5) RED/WHT OV  
RIGHT INPUT GND (6) OV

COLLECTOR SUPPLY (40) ORN/WHT 103V  
BASE FILTER (38) YEL 72.4V  
ZENER SUPPLY (42) RED/WHT 116V  
+75V FILTER (39) RED 73V  
GND (41) BLK OV

LEFT PHONO OUTPUT (3) BLU/OV

RIGHT PHONO OUTPUT (4) WHT/OV

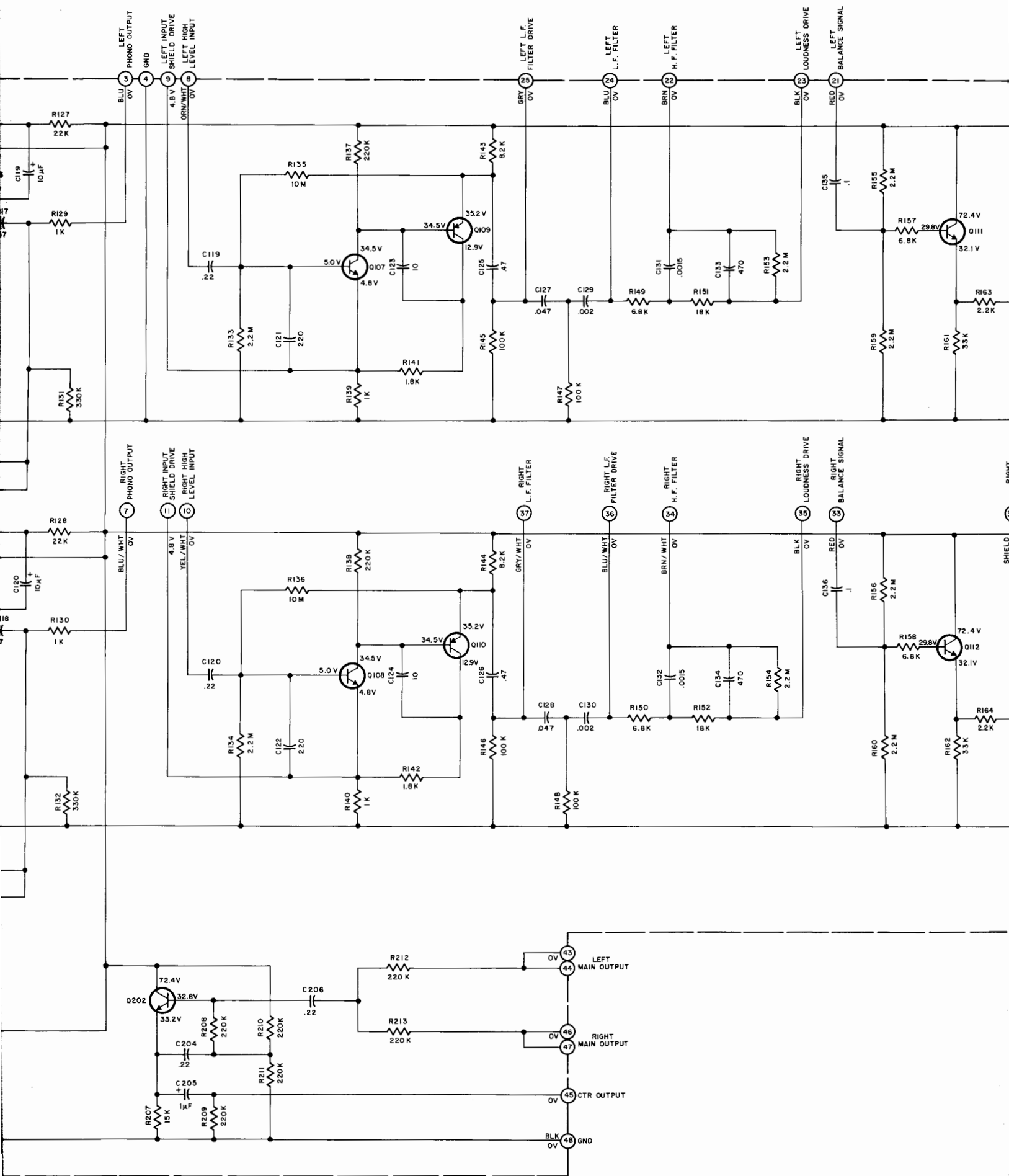

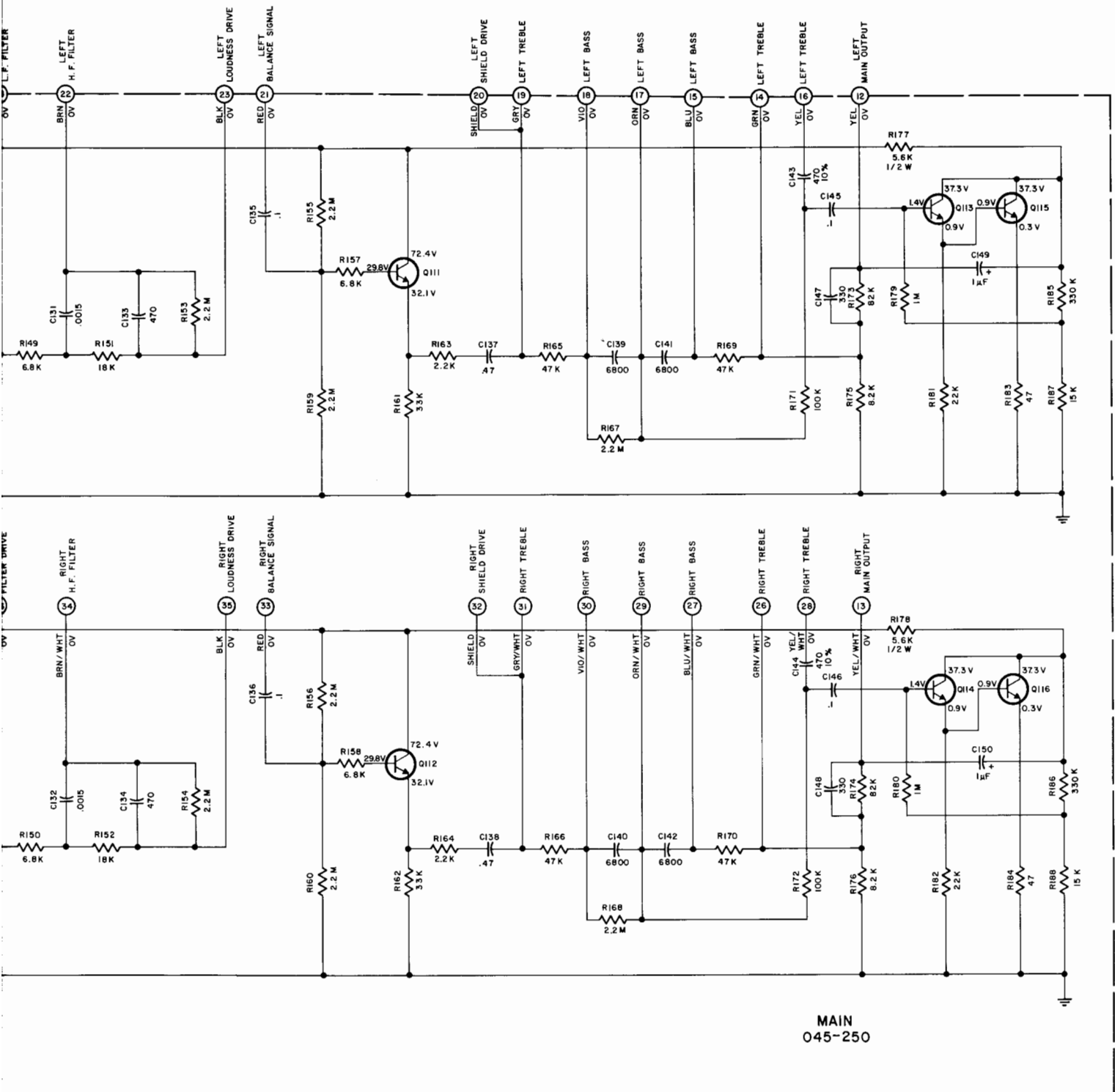

MAIN  
045-250

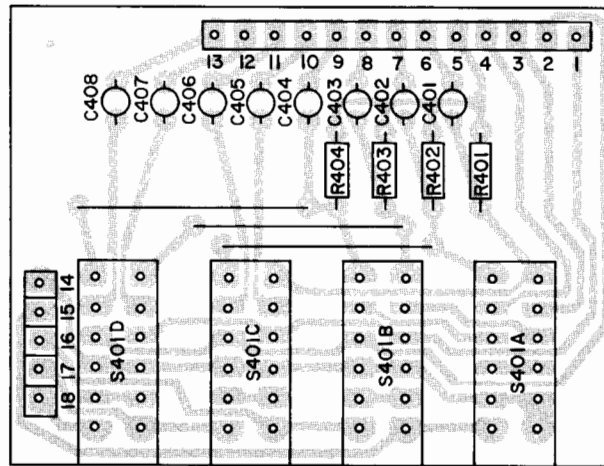
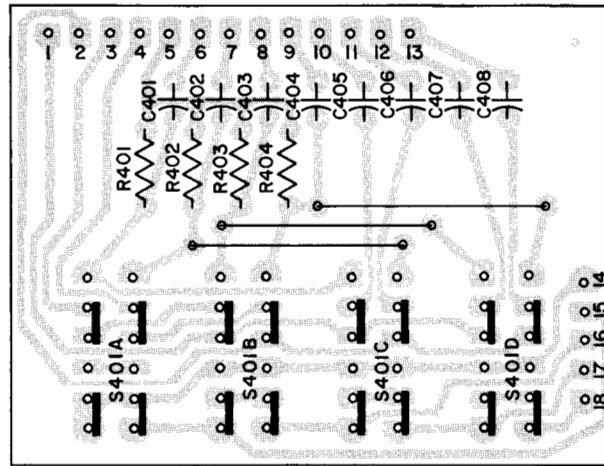

PUSHBUTTON SWITCH PC BOARD  
045-246

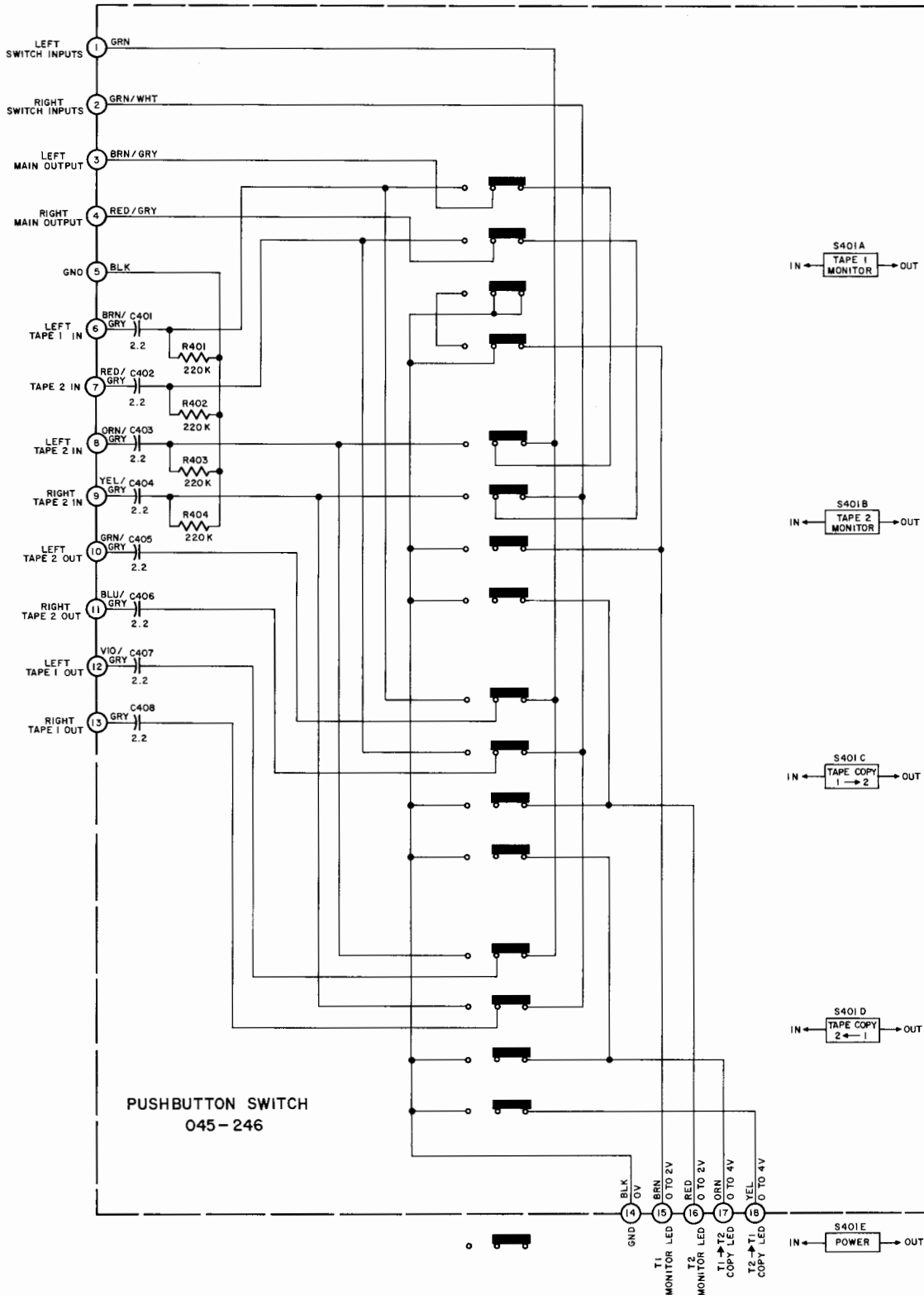

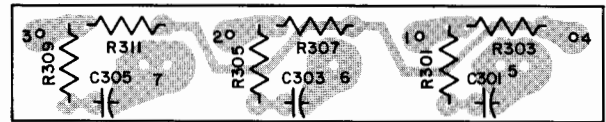
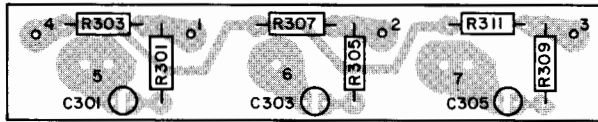

LEFT INPUT TERMINAL PC BOARD  
045-247

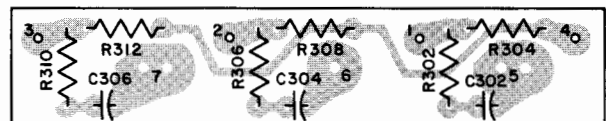
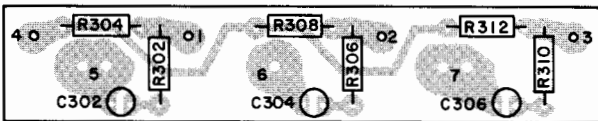

RIGHT INPUT TERMINAL PC BOARD  
045-247

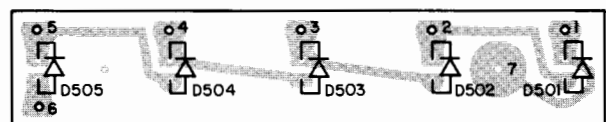
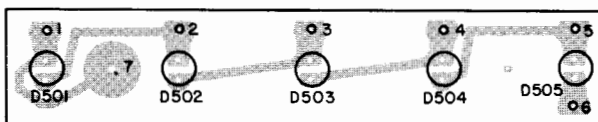

SWITCH INDICATOR PC BOARD  
045-243

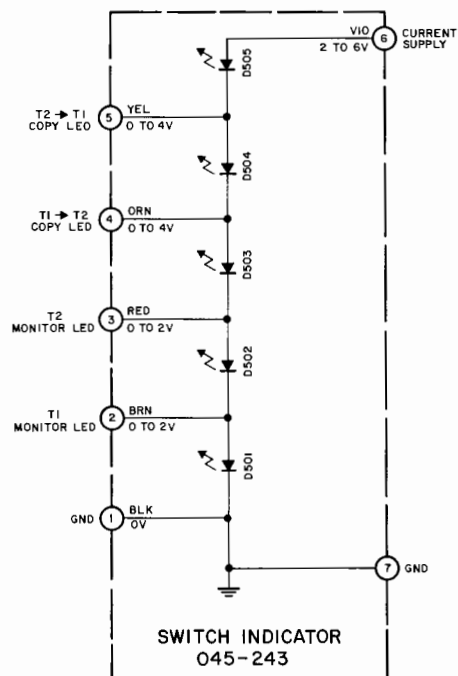
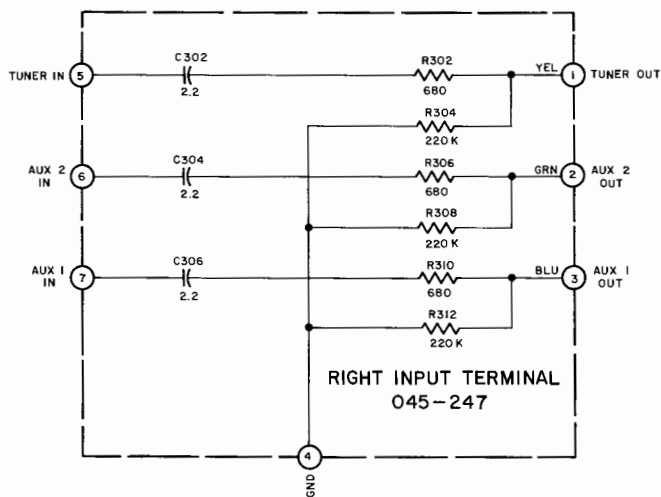
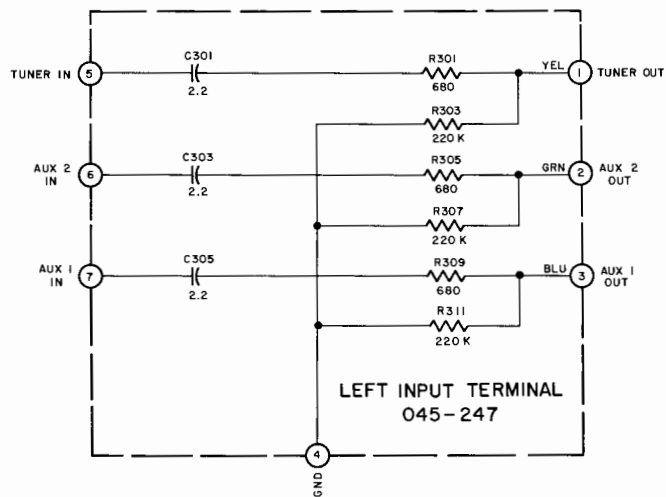



All parts not listed are common items obtainable from radio parts jobbers.

Replacement parts may be obtained when ordered by PART NUMBER from:

McIntosh Laboratory, Inc.  
Customer Service Department  
2 Chambers Street  
Binghamton, New York 13903  
(telephone 607-723-3512)

## CAPACITORS

Symbol Number	Description	Part Number
C9	Elect. 10 $\mu$ F 50V	066-221
C13	Elect. 80/80/150/150 $\mu$ F	066-095

## DIODES

D1,2	Si. Signal diode	070-031
D3	Si. Signal Diode	070-031
D201	Zener 75V	070-025
D501,502	LED Lamp	070-093
D503,504	LED Lamp	070-093
D505	LED Lamp	070-093

## FUSES

F1	Fuse 0.5A Norm Blo	089-009
----	--------------------	---------

## TRANSISTORS

Q101,102	Si. PNP Transistor	132-176
Q103,104	Si. NPN Transistor	132-175
Q105,106	Si. NPN Transistor	132-175
Q107,108	Si. NPN Transistor	132-175
Q109,110	Si. PNP Transistor	132-176
Q111,112	Si. NPN Transistor	132-175
Q113,114	Si. NPN Transistor	132-175
Q115,116	Si. NPN Transistor	132-175
Q201	NPN Power Transistor	132-028
Q202	Si NPN Transistor	132-175

## POTENTIOMETERS

R3	Volume Control	134-319
R4,5	Bal./Loudness Control	134-320

## SWITCHES

S1	Input Selector	146-193
S2	Mode Selector	146-196
S3	LF-HF Filter	146-194
S4	Bass Switch	146-195
S5	Treble Switch	146-195
S6	Speaker Filter Switch	146-194
S401	Pushbutton Switch	150-026

## TRANSFORMERS

T1	Power Transformer	045-217
----	-------------------	---------

## FRONT PANEL &amp; TRIM

	Front Panel Glass	016-165
	End Caps	018-160
	Knob - Volume	090-017
	Knob - Mode	090-156
	Knob - Input	090-156
	Knob - Filters	090-200
	Knob - Speakers	090-201
	Knob - Loudness	090-186
	Knob - Balance	090-187
	Knob - Bass Right	090-200
	Knob - Bass Left	090-201
	Knob - Treble Right	090-200
	Knob - Treble Left	090-201

## MISCELLANEOUS

	Shipping Carton	045-338
	Mounting Temp #100	038-178
	Hardware Package	045-142
	Fuseholder	178-099
	Line Cord	170-019
	Audio Cable	170-015
	Owners Manual	039-033
	Shorting Phono Plug	127-021

REDUCE RFI & ELIMINATE OSCILLATION

MODEL: C 27 Preamplifier

PURPOSE OF MODIFICATION: To reduce sensitivity to RF interference and to eliminate oscillation when using a moving coil phono cartridge.

WHEN MODIFICATION SHOULD BE MADE: Whenever customer is complaining of:

- A. Undersired reception of CB, ham apparatus and man made noise in the phono mode.
- B. Oscillations, when a moving coil cartridge is used.

PARTS REQUIRED:

QUANTITY	PART NUMBER	DESCRIPTION
2	061039	Disc. cap. .003μF, 20% C103, 104
2	141090	Film res. 56K, 5%, 1/4W
4	141041	Film res. 470Ω, 5%, 1/4W

PROCEDURE: All changes are on the main PC board (045250), except step 4.

1. Change C103 and C104 from 470pF 10% to .003μF 20%
2. Remove and replace R115 and R116, 120Ω, 5%, 1/4W with wire jumpers.
3. Locate capacitor C109, Disconnect the lead on C109 that connects to R121. Connect a 56K, 5%, 1/4W resistor in series with the disconnected C109 lead and the circuit board where the C109 lead formerly connected. Do likewise for capacitor C110.
4. Connect right at the phono jacks a film resistor = 470Ω, 5%, 1/4W in series with the leads connected to these phono jacks.

(OVER)

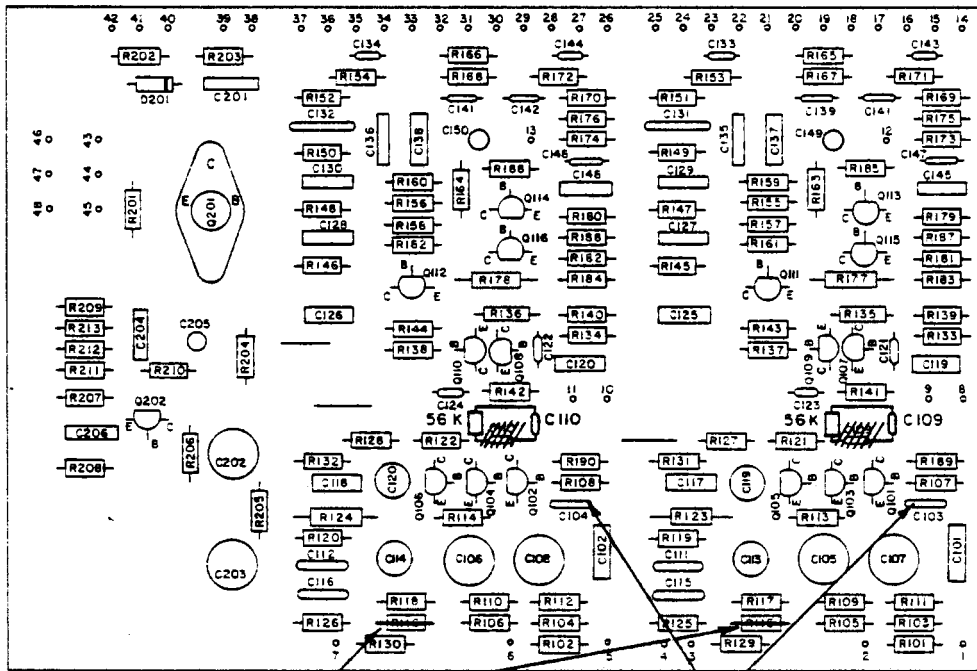
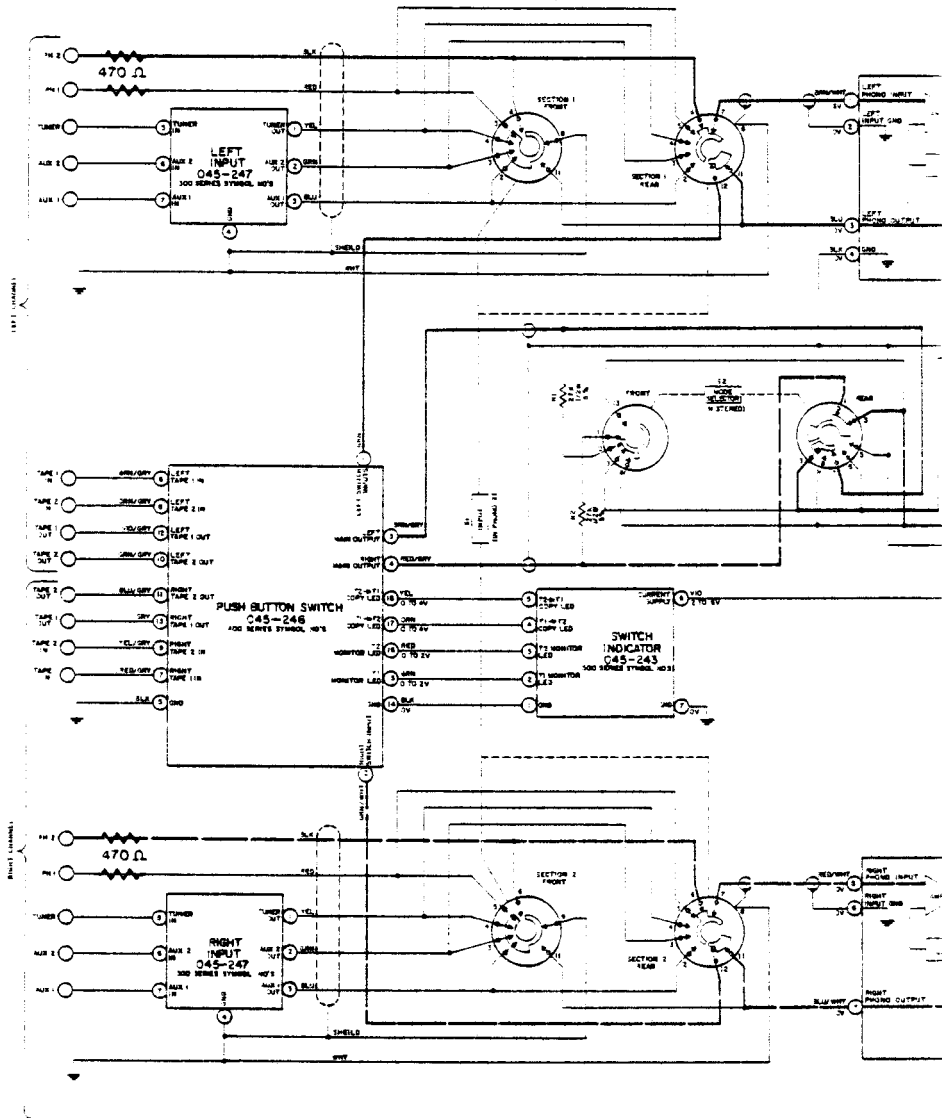

REPLACE WITH JUMPERS MAIN PC BOARD O45250 REPLACE WITH .003 μf, 20% DISCAPS